

The background of the slide is a microscopic image of stained cells. The cells are stained with various colors, including pink, blue, and purple, against a light background. The cells are scattered across the slide, with some appearing more prominent than others. The overall appearance is that of a biological specimen under a microscope.

MCAS Review Cells

Mr. Lee
Room 320

2

The table below lists the concentrations of water inside and outside a cell under four different conditions.

Condition	Water Concentration in Cell	Water Concentration in Environment
1	90%	95%
2	90%	100%
3	95%	90%
4	95%	95%

Under which condition will the cell experience a net loss of water to its environment?

- A. Condition 1
- B. Condition 2
- C. Condition 3
- D. Condition 4



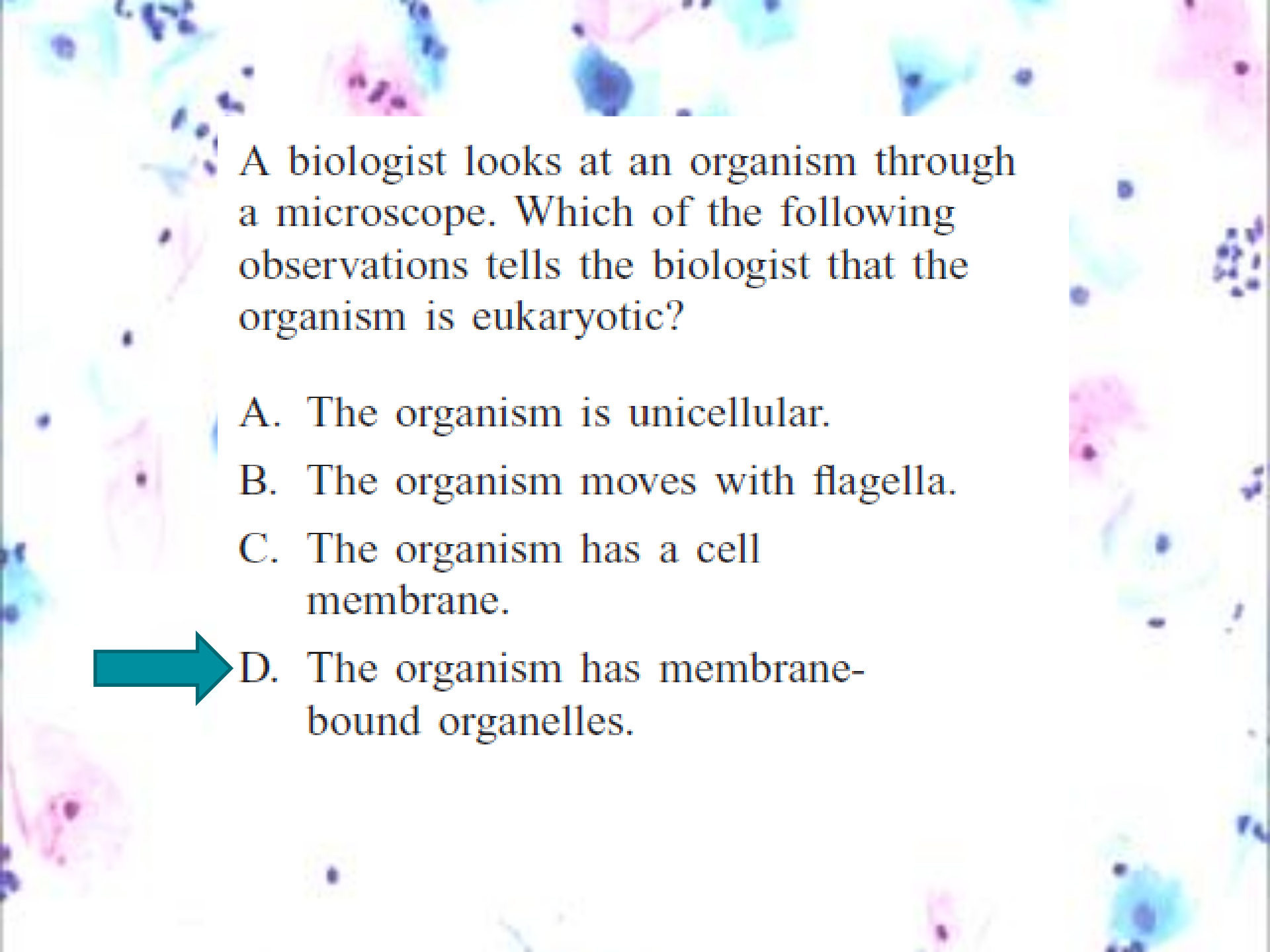

A biologist looks at an organism through a microscope. Which of the following observations tells the biologist that the organism is eukaryotic?

- A. The organism is unicellular.
- B. The organism moves with flagella.
- C. The organism has a cell membrane.
-  D. The organism has membrane-bound organelles.

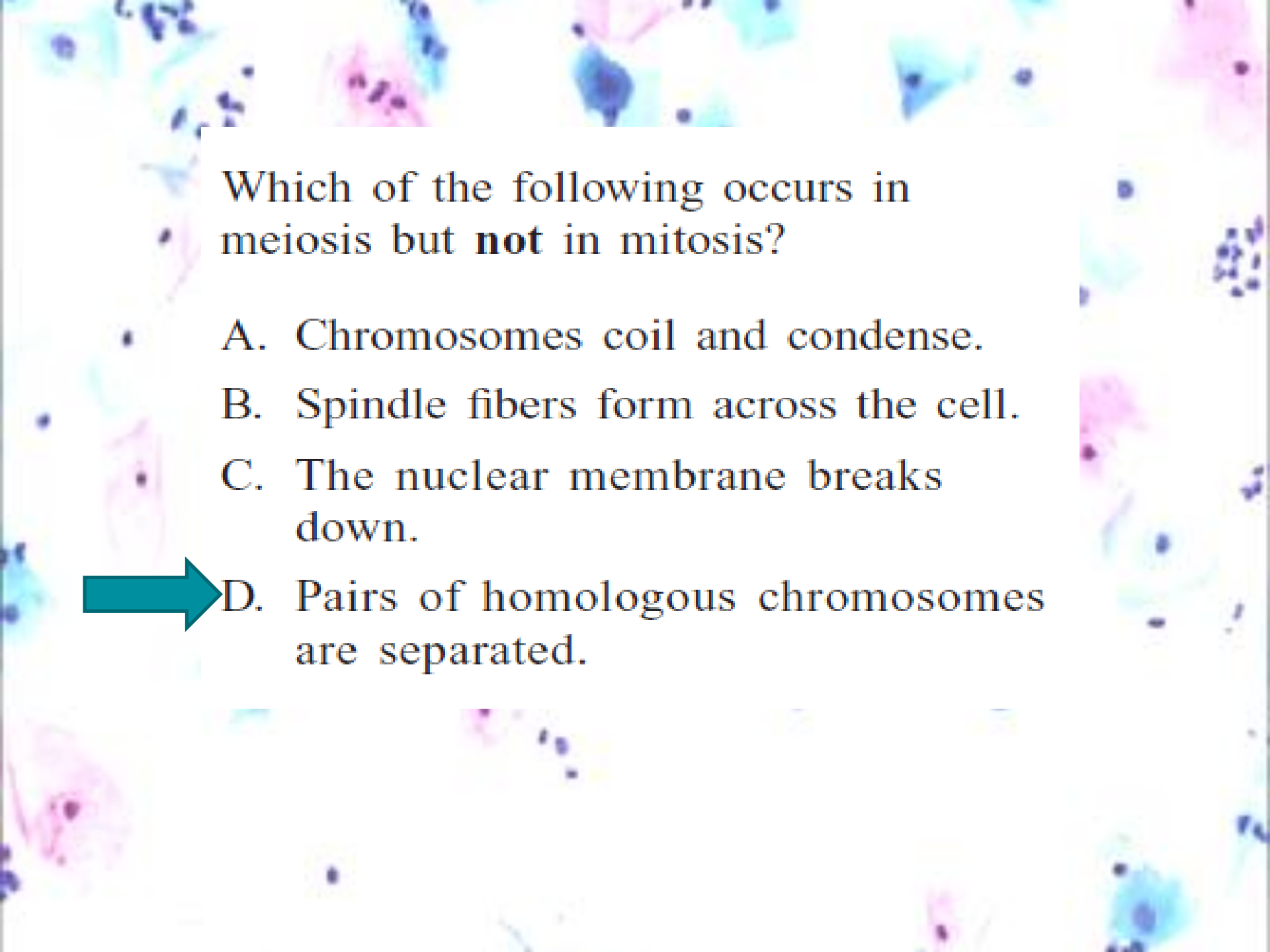

Which of the following occurs in meiosis but **not** in mitosis?

- A. Chromosomes coil and condense.
- B. Spindle fibers form across the cell.
- C. The nuclear membrane breaks down.
-  D. Pairs of homologous chromosomes are separated.

The figure below shows an egg cell and a sperm cell.

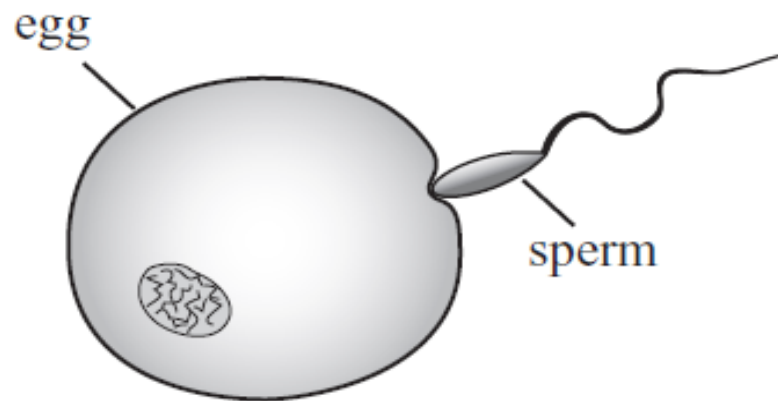

Which of the following is represented by this figure?



- A. the formation of a zygote
- B. mitotic division of nuclei
- C. the production of gametes
- D. translation of genetic information

Both photosynthesis and cellular respiration involve all of the following **except**



A. chlorophyll.

B. glucose.

C. oxygen.

D. water.

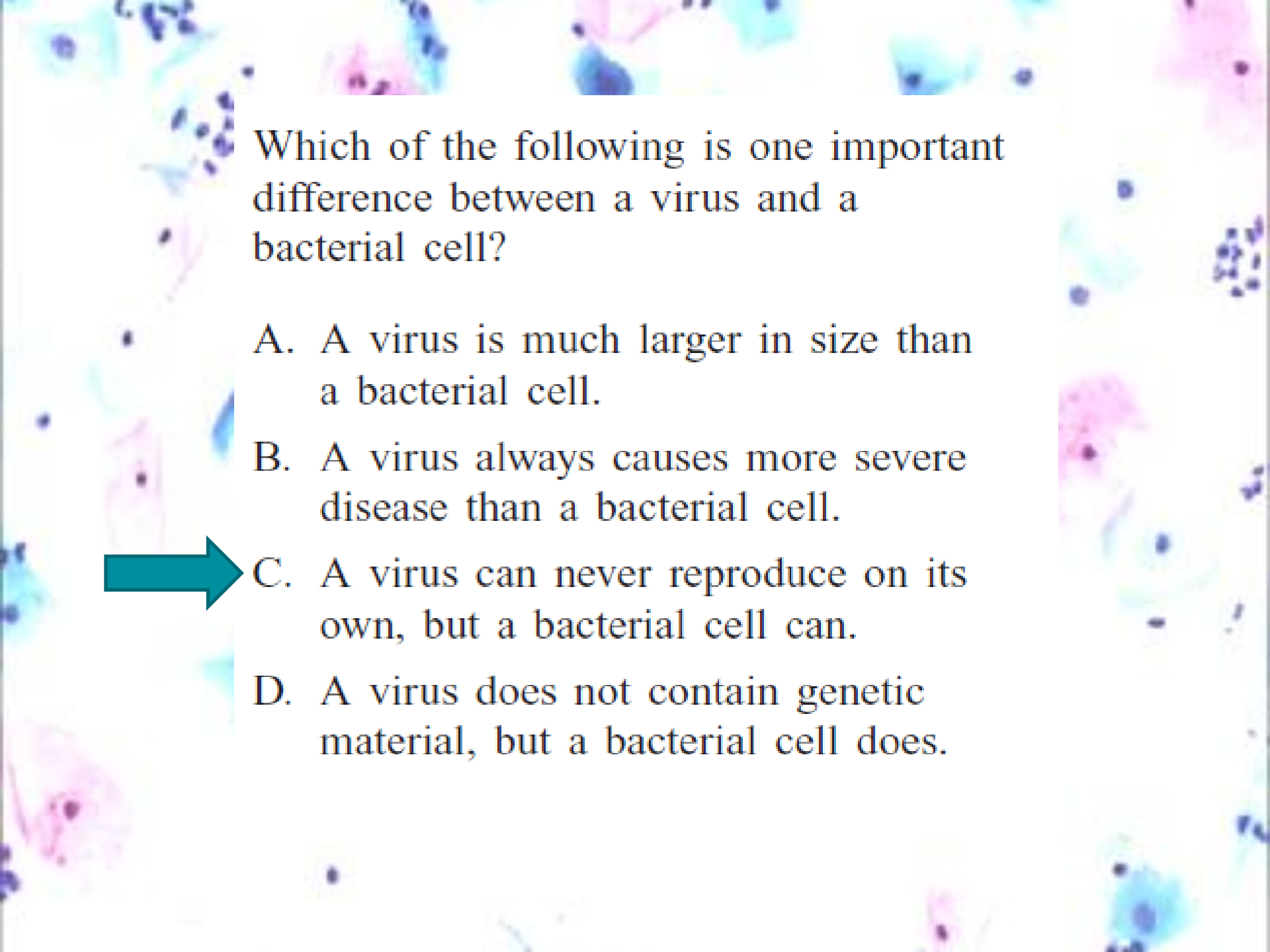

Which of the following is one important difference between a virus and a bacterial cell?

- A. A virus is much larger in size than a bacterial cell.
- B. A virus always causes more severe disease than a bacterial cell.
-  C. A virus can never reproduce on its own, but a bacterial cell can.
- D. A virus does not contain genetic material, but a bacterial cell does.

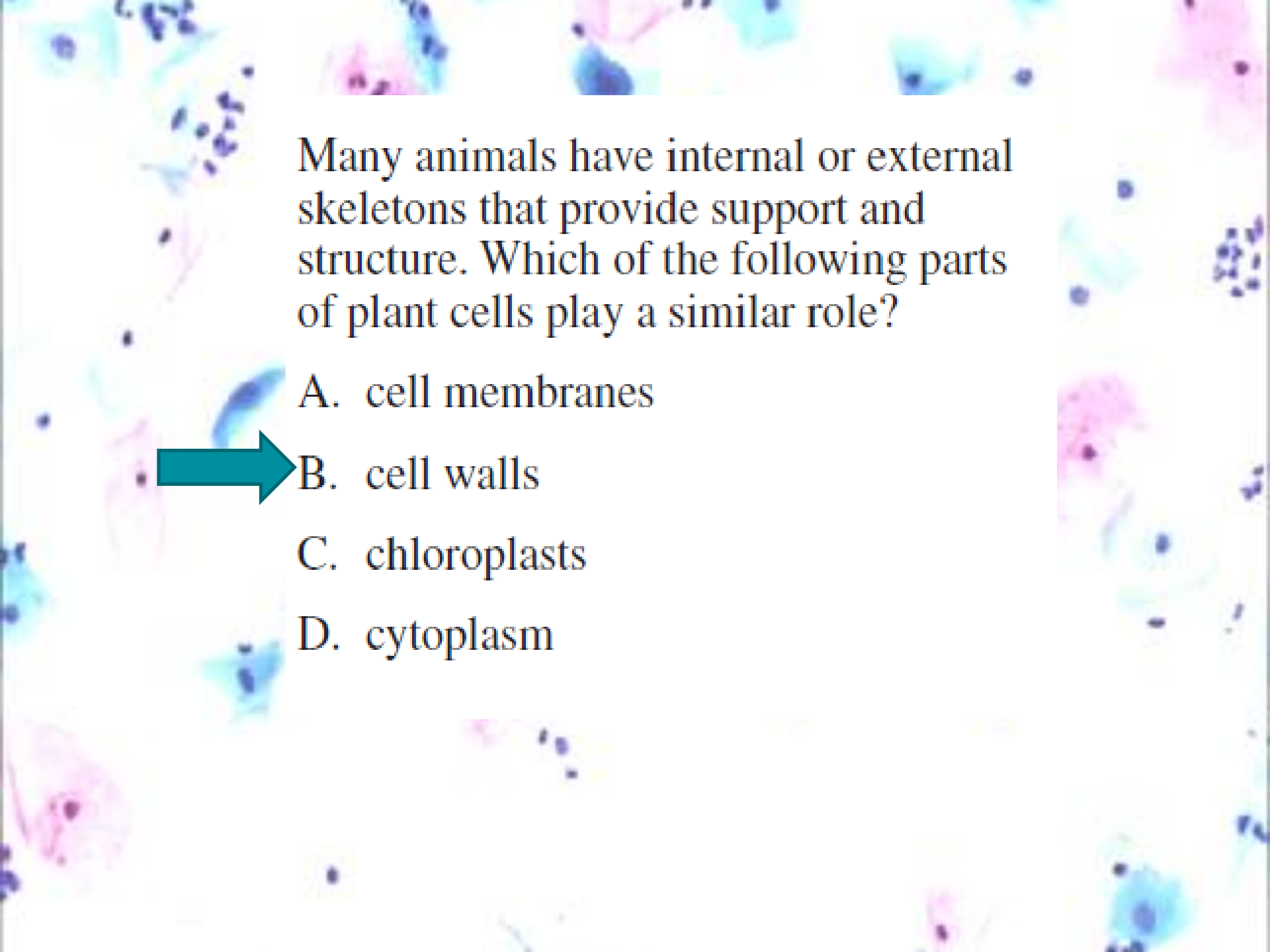
A microscopic view of plant cells, likely from an onion skin, stained with a blue dye. The cells are roughly rectangular and arranged in a brick-like pattern. A text overlay is positioned in the upper right quadrant of the image.

Many animals have internal or external skeletons that provide support and structure. Which of the following parts of plant cells play a similar role?

A. cell membranes



B. cell walls

C. chloroplasts

D. cytoplasm

Cyanide is a powerful poison because it inhibits an enzyme in mitochondria, preventing the transfer of energy during one of the steps in cellular respiration. This poison would **directly** affect the production of which of the following molecules?

- 
- A. ATP
 - B. glucose
 - C. oxygen
 - D. RNA

Which of the following is an example of a prokaryotic organism?



A. bacterium

B. celery

C. horse

D. mushroom

The natural cycling of oxygen between organisms and their environment is **most** directly accomplished through which of the following pairs of processes?

- A. fermentation and oxidation
- B. transpiration and evaporation
- C. precipitation and condensation
-  D. photosynthesis and respiration

22

The reaction catalyzed by the bacterial enzyme β -galactosidase forms a dark-colored end-product when the cells are grown on a particular agar medium. As more product is formed, the cells become darker.

Students performed an experiment to determine the optimum pH for activity of this enzyme. Their results are shown in the illustration of bacterial colonies below.

Bacterial Colony Color as a Function of pH

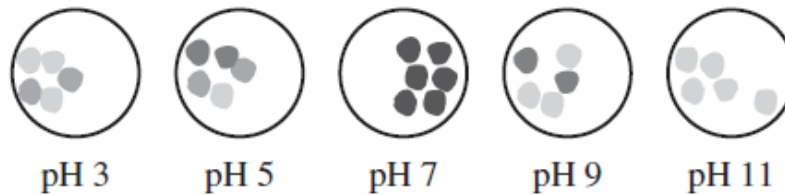

Based on these data, the students should conclude that β -galactosidase functions **best** at which pH?

- A. 5
- B. 7
- C. 9
- D. 11



The molecule ATP is composed of elements commonly found in organic molecules. Which of the following is one of these elements?

- A. aluminum
- B. calcium
-  C. phosphorus
- D. tin

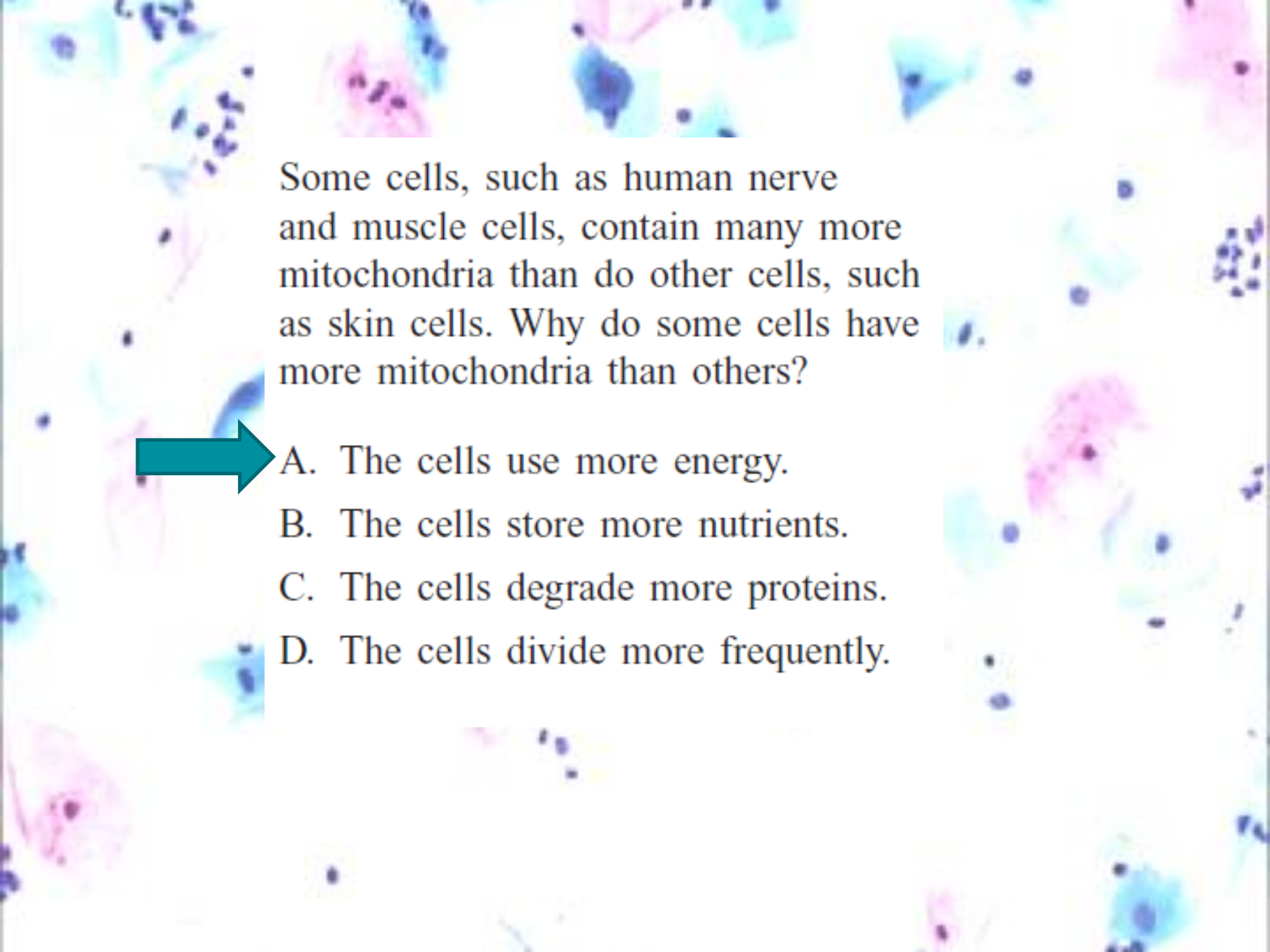

Some cells, such as human nerve and muscle cells, contain many more mitochondria than do other cells, such as skin cells. Why do some cells have more mitochondria than others?

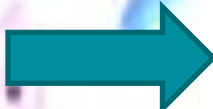
- 
- A. The cells use more energy.
 - B. The cells store more nutrients.
 - C. The cells degrade more proteins.
 - D. The cells divide more frequently.

The graph below shows the amount of ATP produced in a cell during a period of time.

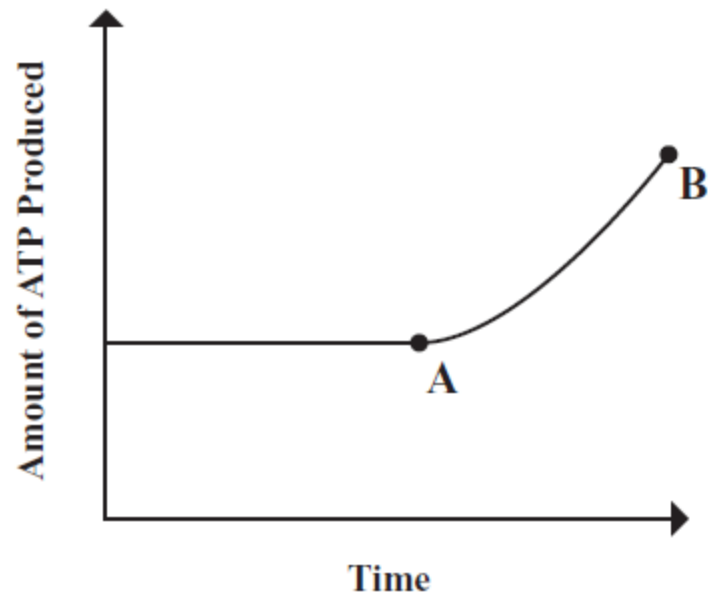

According to the graph, which of the following processes **must** have increased between points A and B?

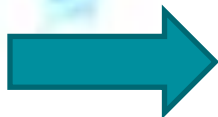

- A. cellular respiration
- B. cytokinesis
- C. DNA replication
- D. meiosis

In one of the steps of the carbon cycle, a person exhales a molecule of carbon dioxide (CO_2) into the atmosphere. Which of the following is **most likely** to happen next to the atom of carbon in this molecule?

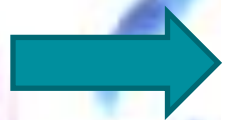

- A. It may be used as part of a sugar in a plant.
- B. It may become part of a protein in an animal.
- C. It may be consumed as a fossil fuel is burned.
- D. It may be decomposed into carbon and oxygen by a bacterium.

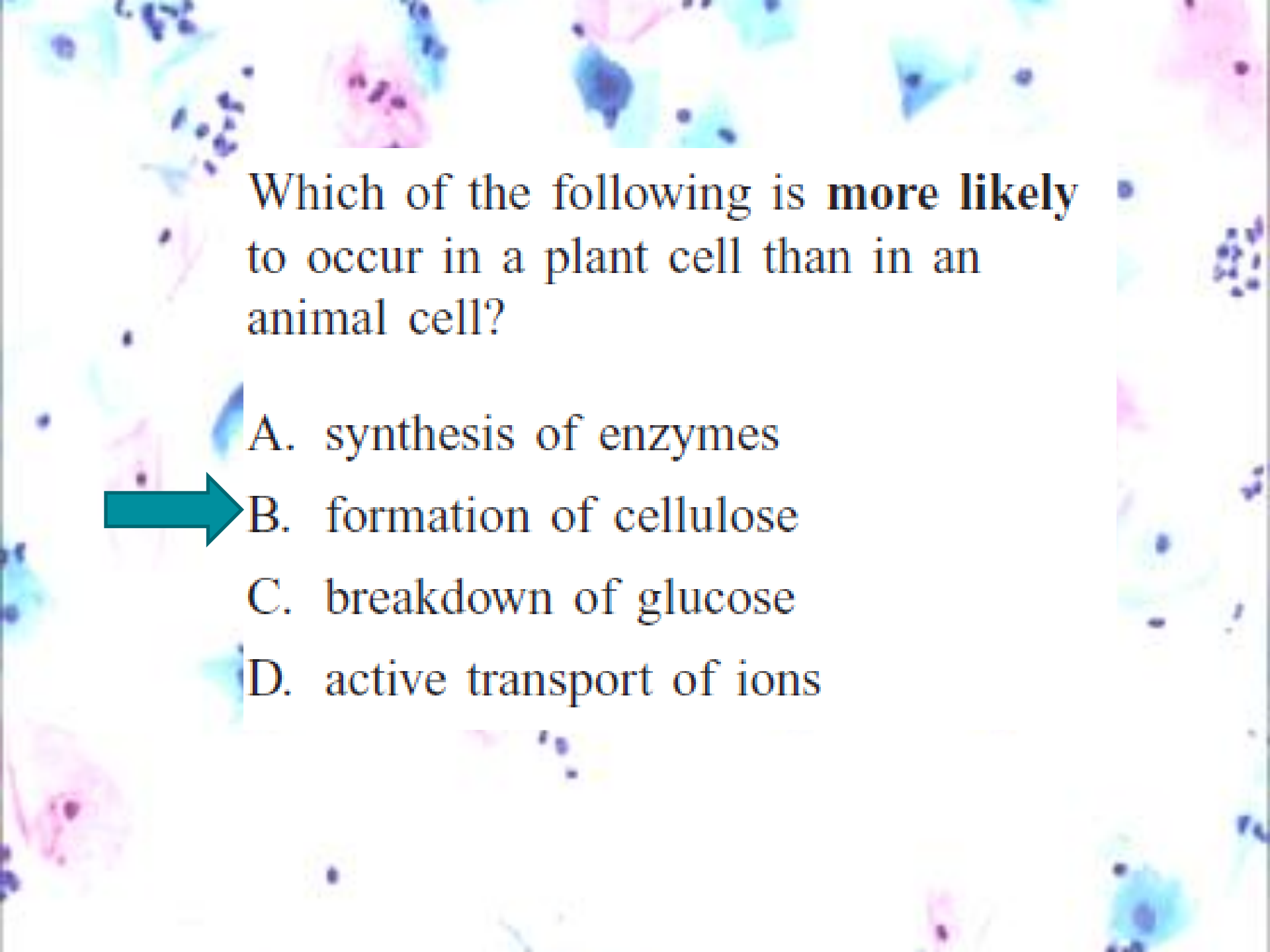
A microscopic image of plant cells, likely from an onion skin, showing various cell structures. The cells are stained with a blue dye (likely methylene blue) and a pink dye (likely iodine). The question is overlaid on the image.

Which of the following is **more likely** to occur in a plant cell than in an animal cell?

A. synthesis of enzymes

 B. formation of cellulose

C. breakdown of glucose

D. active transport of ions

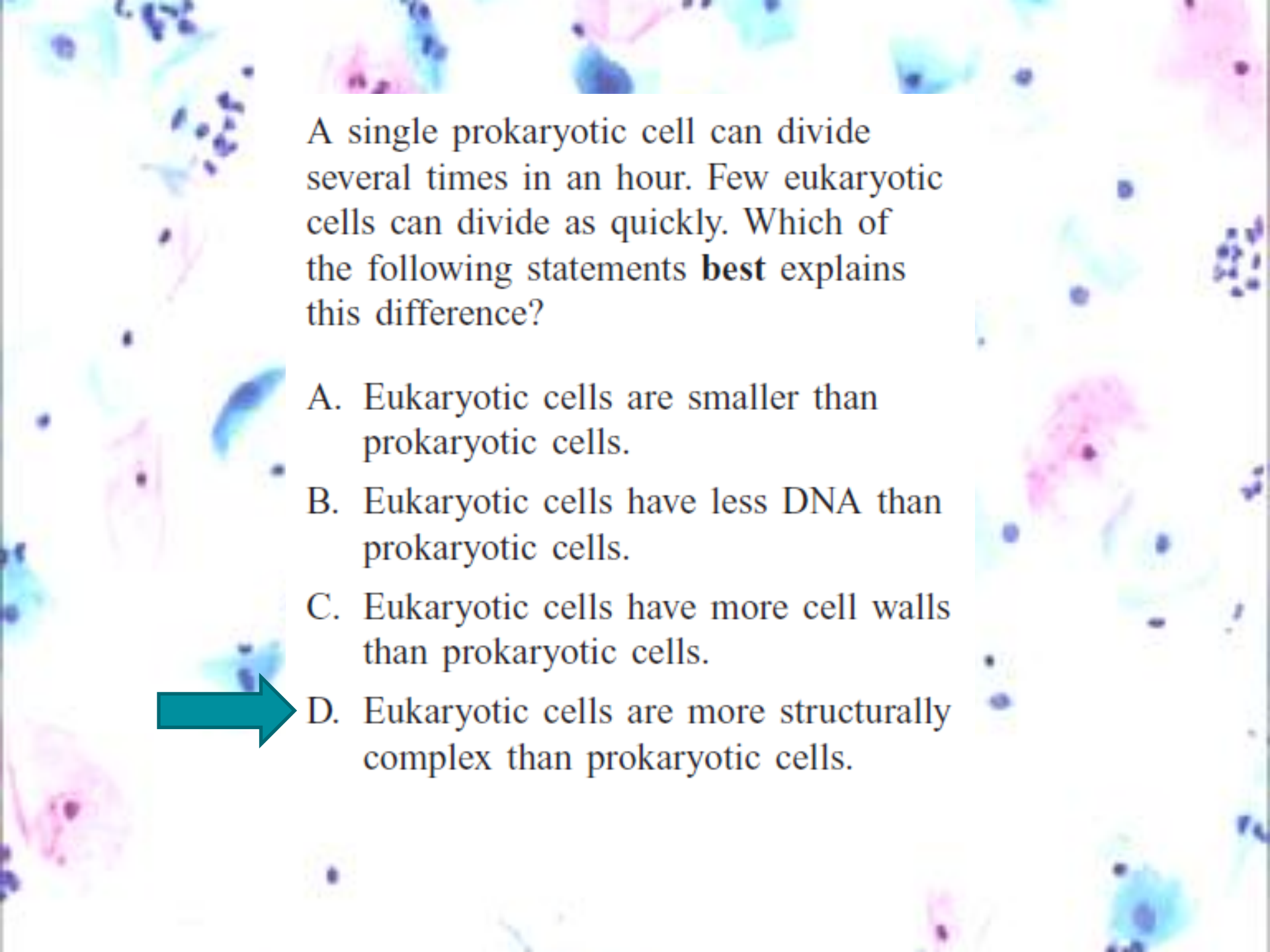

A single prokaryotic cell can divide several times in an hour. Few eukaryotic cells can divide as quickly. Which of the following statements **best** explains this difference?

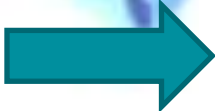
- A. Eukaryotic cells are smaller than prokaryotic cells.
- B. Eukaryotic cells have less DNA than prokaryotic cells.
- C. Eukaryotic cells have more cell walls than prokaryotic cells.
-  D. Eukaryotic cells are more structurally complex than prokaryotic cells.

20

The diagram below illustrates how plant root cells take in mineral ions from the surrounding soil.

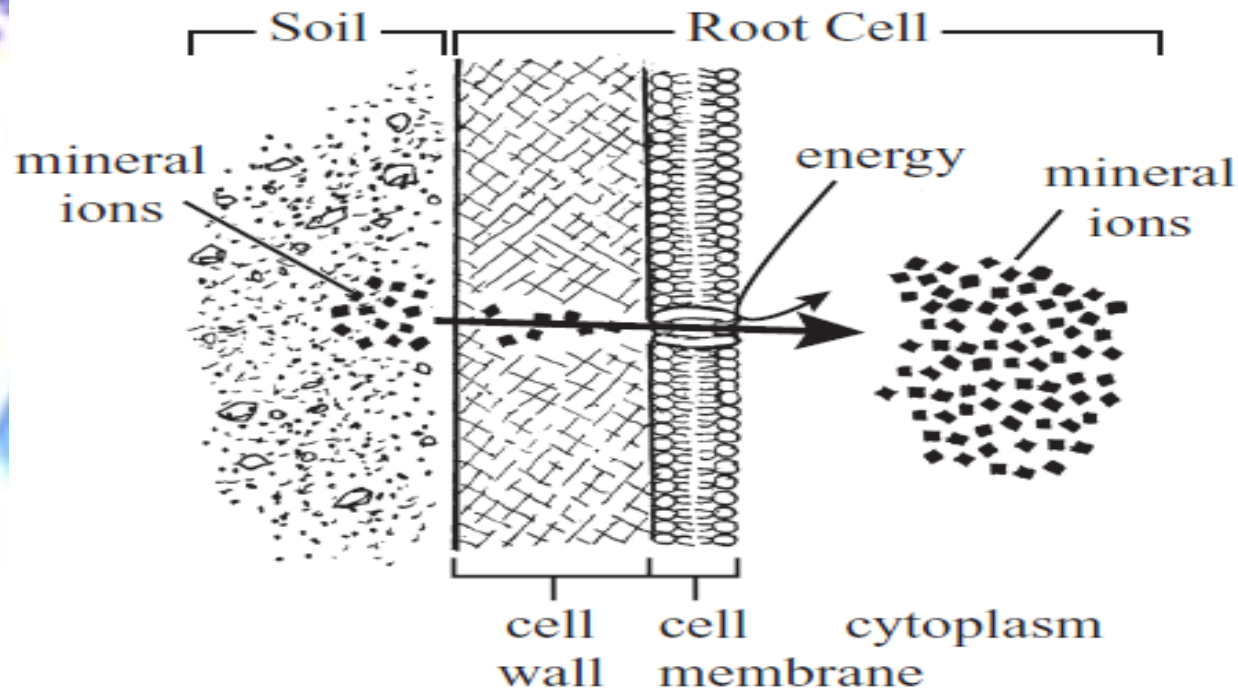

Which of the following processes is illustrated?



- A. active transport
- B. diffusion
- C. osmosis
- D. passive filtration

Which of the following occurs during photosynthesis?

- A. CO_2 is used to produce water.
- B. CO_2 is absorbed by mitochondria.
-  C. CO_2 and H_2O are converted to carbohydrates.
- D. CO_2 and H_2O are combined into carbonic acid.

Human tears contain the enzyme lysozyme, which damages the cell walls of bacteria. Which of the following statements about lysozyme is **most** accurate?

- A. Lysozyme causes mutations in bacterial cell wall molecules.
- B. Lysozyme is destroyed as it digests bacterial cell wall molecules.
-  C. Lysozyme breaks a specific type of bond in a bacterial cell wall molecule.
- D. Lysozyme is converted to another chemical by a bacterial cell wall molecule.

Which of the diagrams below **best** represents the net movement of molecules in osmosis?

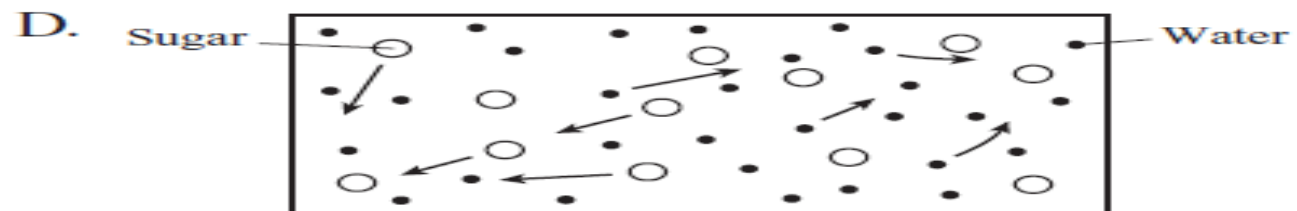
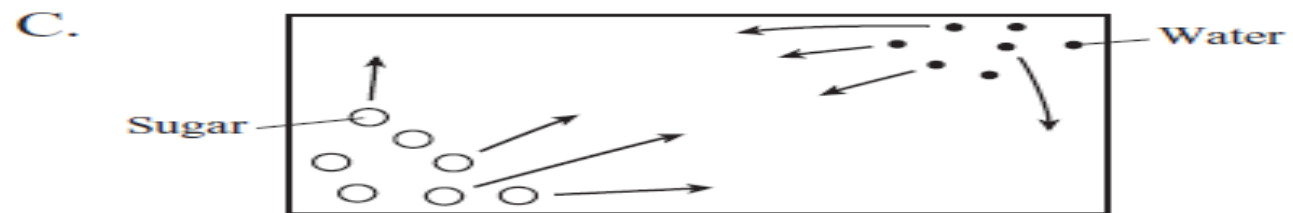
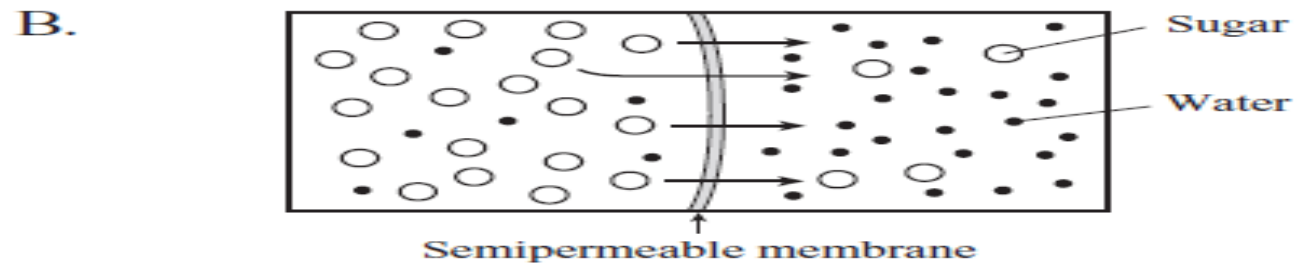
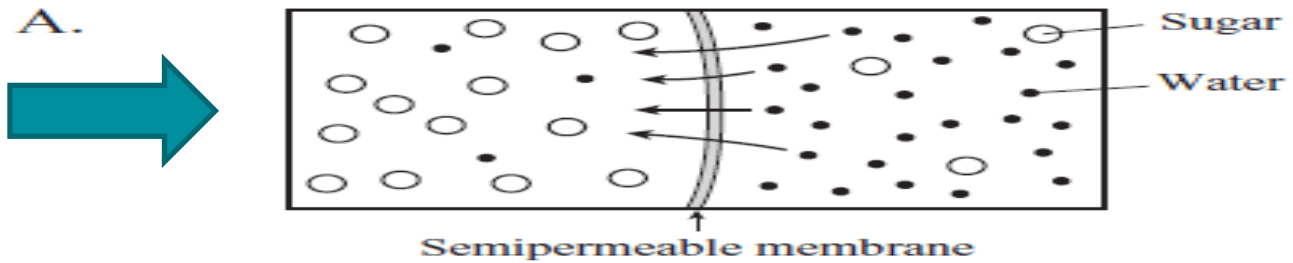

The diagrams below illustrate two different types of cell division.

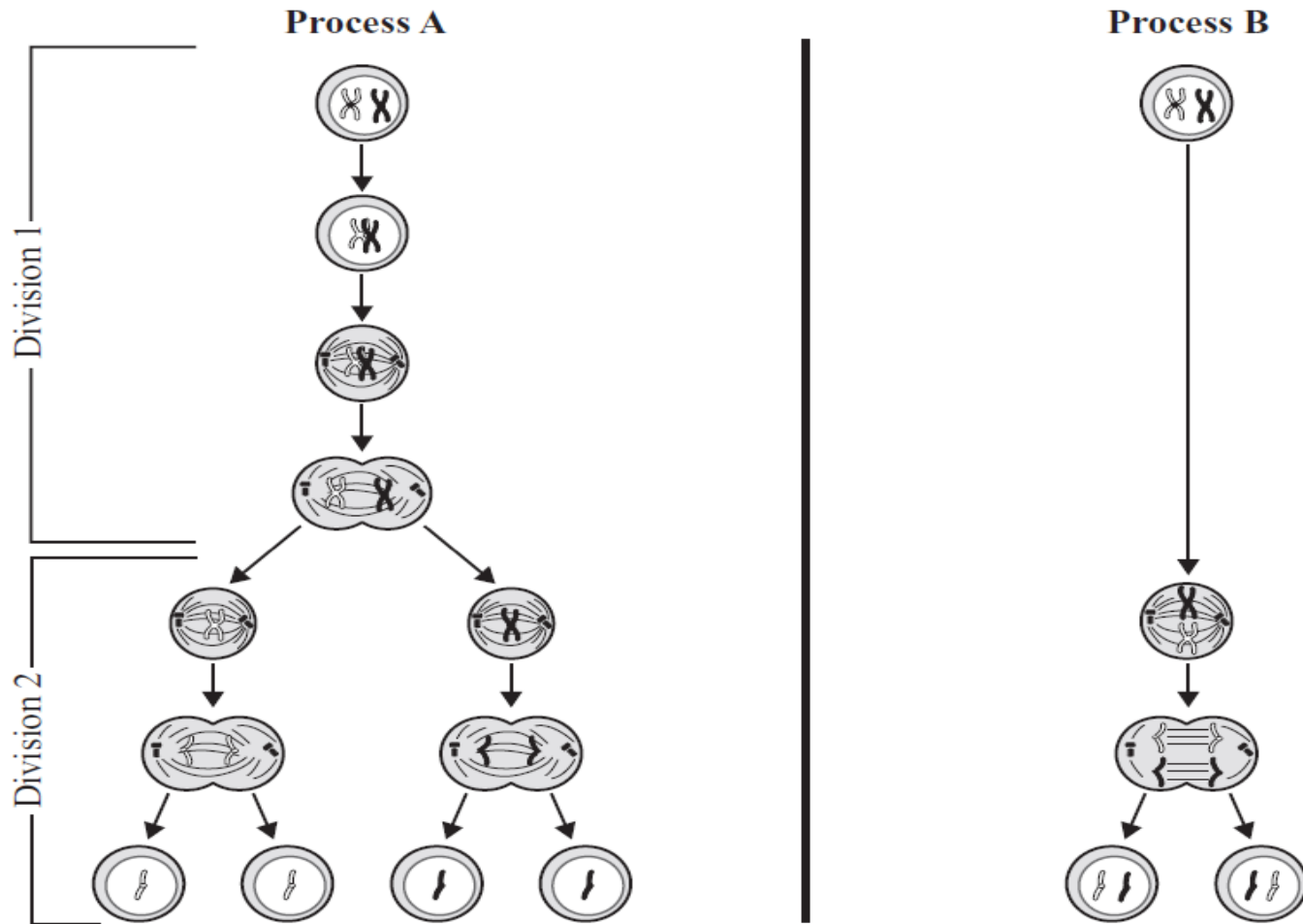

- Identify which diagram shows the process of mitosis and which diagram shows the process of meiosis.
- Explain **three** differences between mitosis and meiosis. Your answer should include differences found in the actual processes and differences found in the cells resulting from each type of division.

In which of the following ways are photosynthesis and cellular respiration alike?

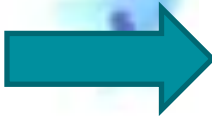
- A. Both processes produce glucose.
- B. Both processes consume carbon dioxide.
- C. Both processes take place in chloroplasts.
-  D. Both processes involve energy transformations.

A cross section of part of a Golgi complex is shown below.

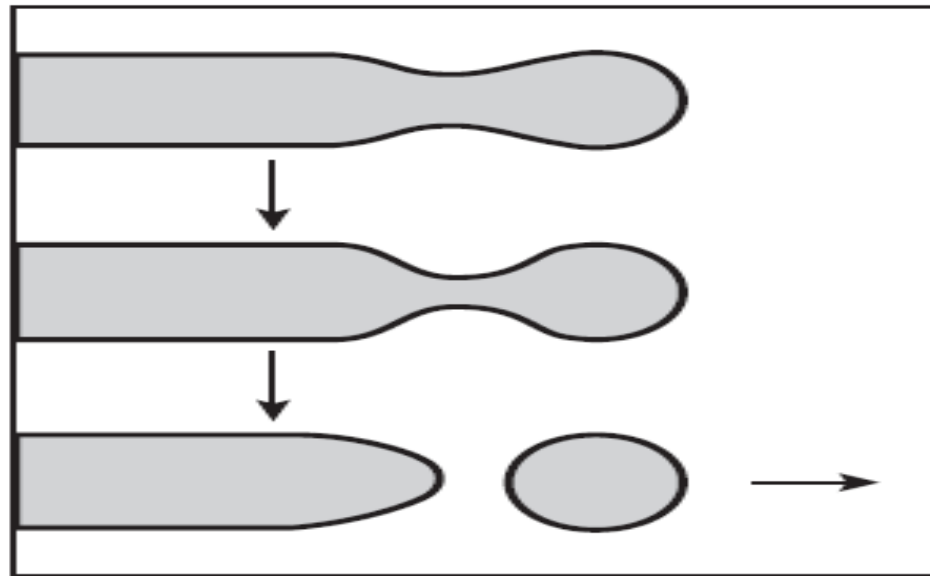

Part of the membrane of the Golgi complex pinches off and moves away. Which of the following is a function of this process?

- A. to release energy from ATP
-  B. to deliver proteins to other locations in the cell
- C. to collect amino acids for use in protein synthesis
- D. to send messages about cell requirements to the nucleus

A partial diagram of a reproductive process is shown below.

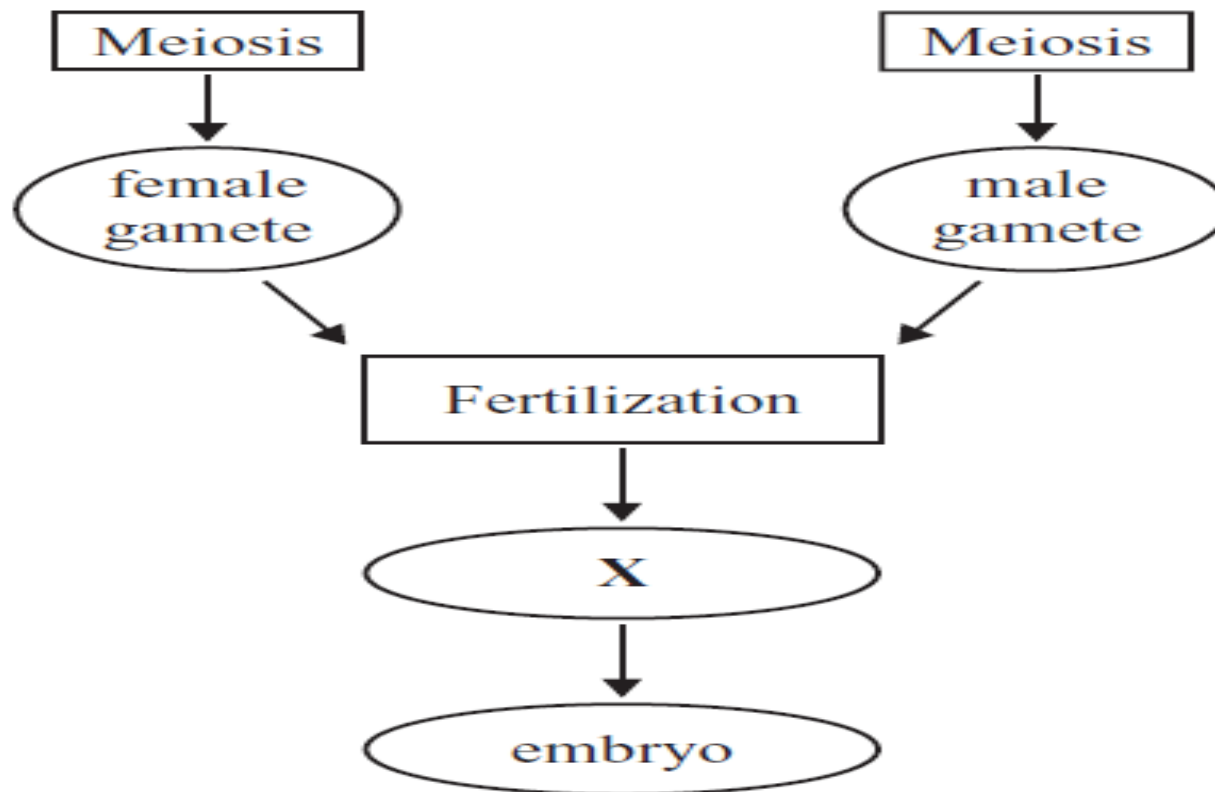

Which of the following labels belongs in the oval marked **X**?

- A. egg
- B. fetus
- C. sperm
- D. zygote



Which of the following **best** describes the formation of a zygote?

- 
- A. A sperm cell nucleus and an egg cell nucleus fuse.
 - B. A cell's DNA replication and mitosis are accelerated.
 - C. A succession of cell divisions produces a solid mass of cells.
 - D. A cell with 46 chromosomes divides to form cells with 23 chromosomes each.

Which of the following functions does active transport perform in a cell?

- A. packaging proteins for export from the cell
- B. distributing enzymes throughout the cytoplasm
-  C. moving substances against a concentration gradient
- D. equalizing the concentration of water inside and outside the cell

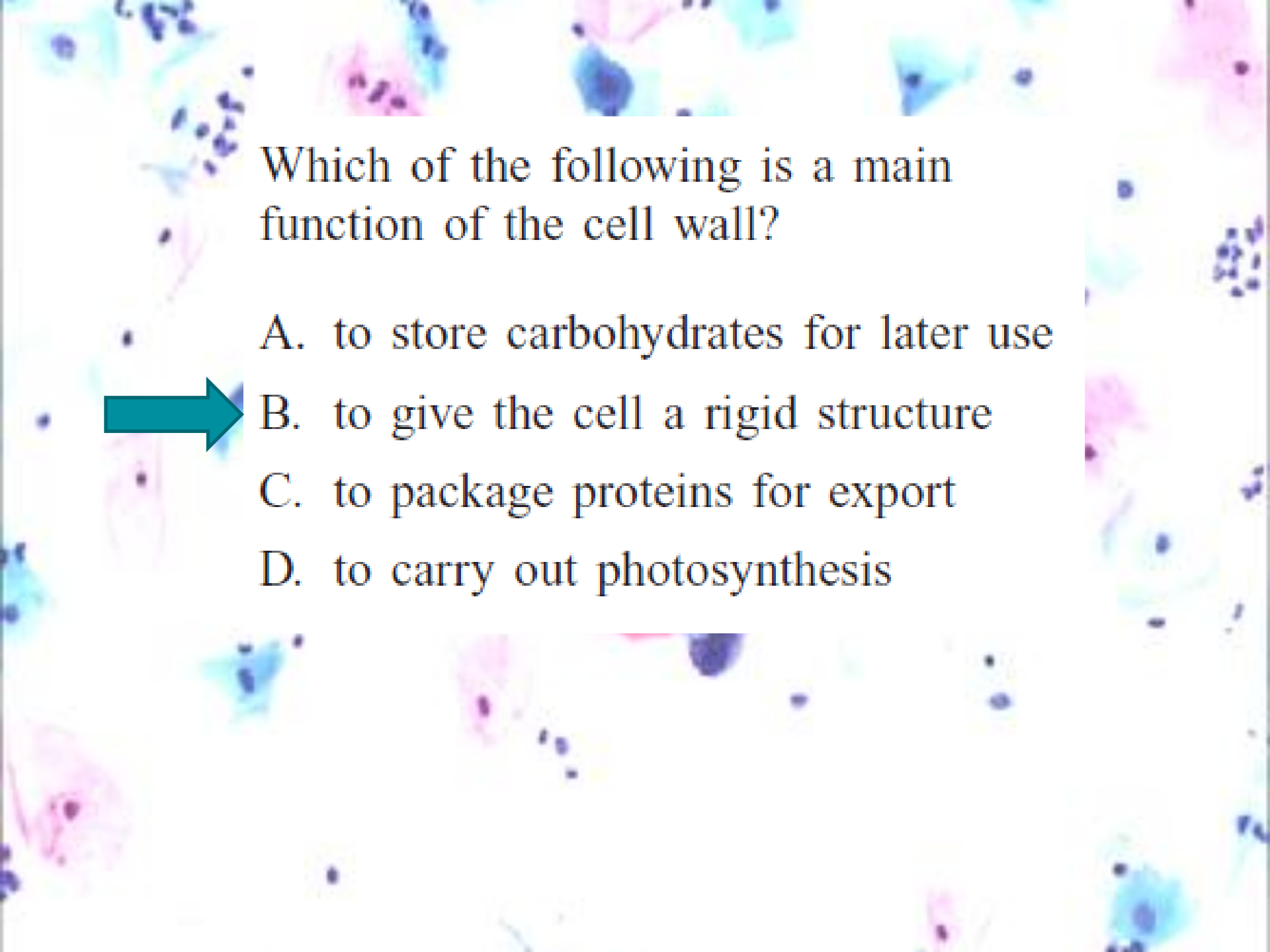

Which of the following is a main function of the cell wall?

A. to store carbohydrates for later use



B. to give the cell a rigid structure

C. to package proteins for export

D. to carry out photosynthesis

Which process do the animals in the food web use to convert energy from food into ATP?



A. cellular respiration

B. osmosis

C. photosynthesis

D. transcription

Which of the following statements correctly matches a cell part with its function?

- A. The cell membrane packages lipids for export.
- B. The mitochondria perform photosynthesis.
-  C. The lysosome digests molecules.
- D. The nucleus produces energy.

When a person exercises, the rate of cellular respiration increases to supply the body with more energy in the form of ATP. Mitochondria require oxygen to carry out cellular respiration.

Describe how the respiratory, circulatory, and muscular systems interact to transport a molecule of oxygen from the air to a mitochondrion. Be sure to discuss all three systems in your response.

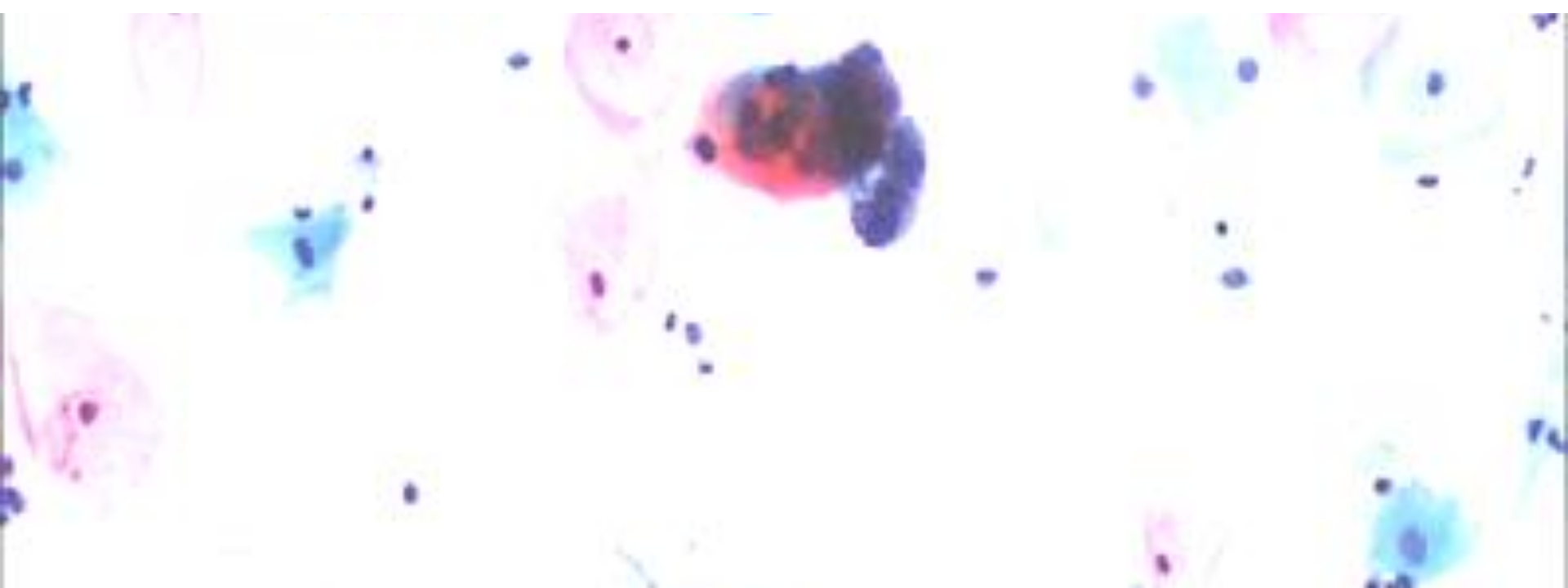

Which of the following processes releases **primarily** oxygen into the atmosphere?

- A. combustion
- B. osmosis
-  C. photosynthesis
- D. respiration

A tomato plant in a greenhouse was found to be infected with tobacco mosaic virus. A few weeks later, nearby plants were also found to be infected with the virus.

Which of the following **best** describes how the virus reproduced?

- A. The virus made its own spores.
- B. The virus produced seeds in the tomatoes.
-  C. The virus used the host plant's resources and machinery to reproduce.
- D. The virus immediately killed the host plant and was free to reproduce.

When gametes are produced from a parent cell during normal meiosis, which of the following describes the number of chromosomes in each resulting cell?

- A. Each resulting cell has the same number of chromosomes as the parent cell.
- B. Each resulting cell has twice the number of chromosomes as the parent cell.
-  C. Each resulting cell has one-half the number of chromosomes as the parent cell.
- D. Each resulting cell has one-fourth the number of chromosomes as the parent cell.

Which of the following **most likely** happens in the cells of a person running in the Boston Marathon?

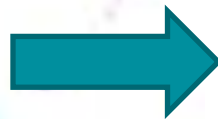

- A. The respiration rate increases to produce more ATP.
- B. The replication rate increases to produce more DNA.
- C. The photosynthesis rate increases to produce more sugars.
- D. The cell division rate increases to produce more muscle fibers.

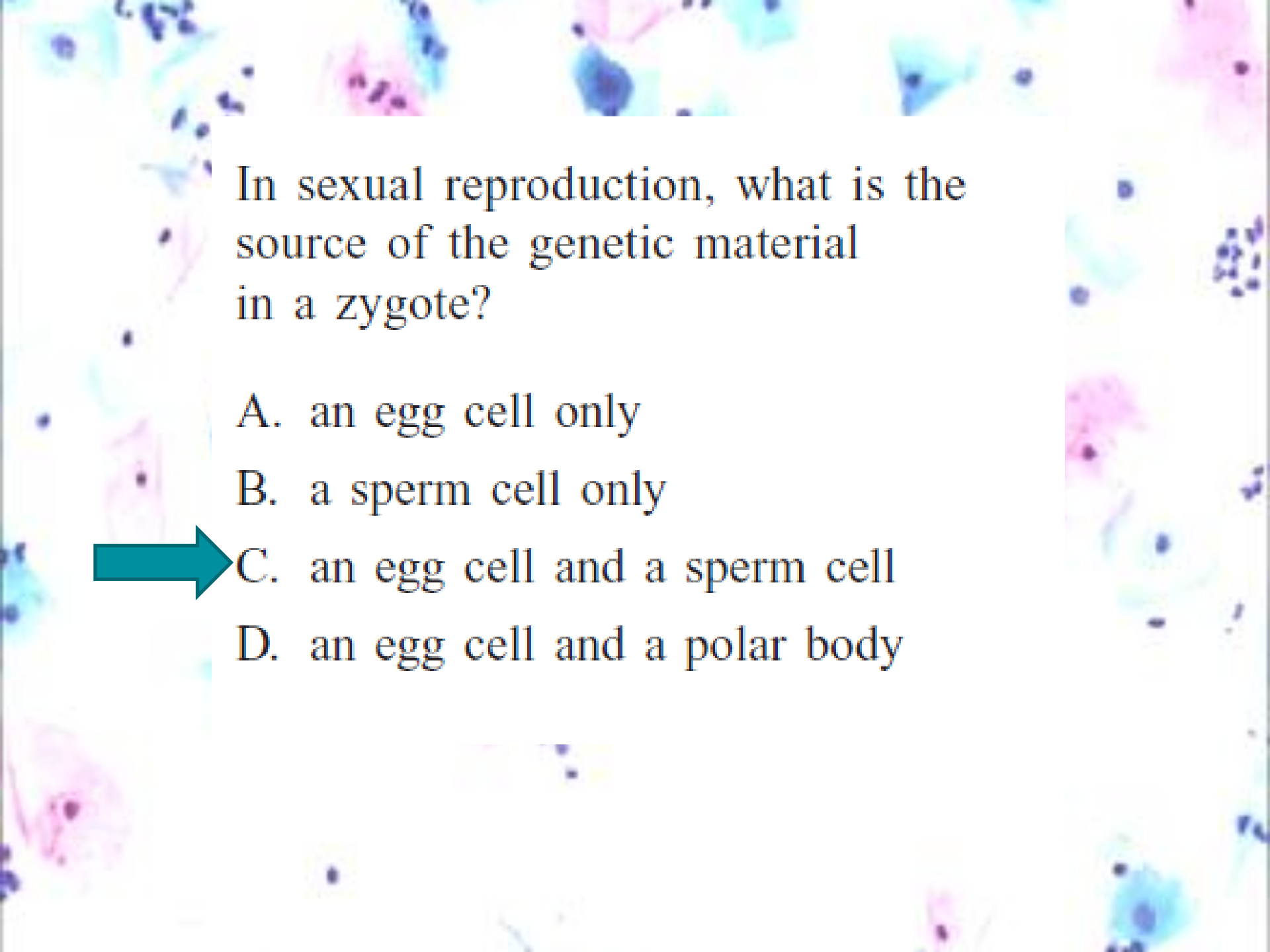

In sexual reproduction, what is the source of the genetic material in a zygote?

A. an egg cell only

B. a sperm cell only

 C. an egg cell and a sperm cell

D. an egg cell and a polar body

The illustrations below represent two different cells.

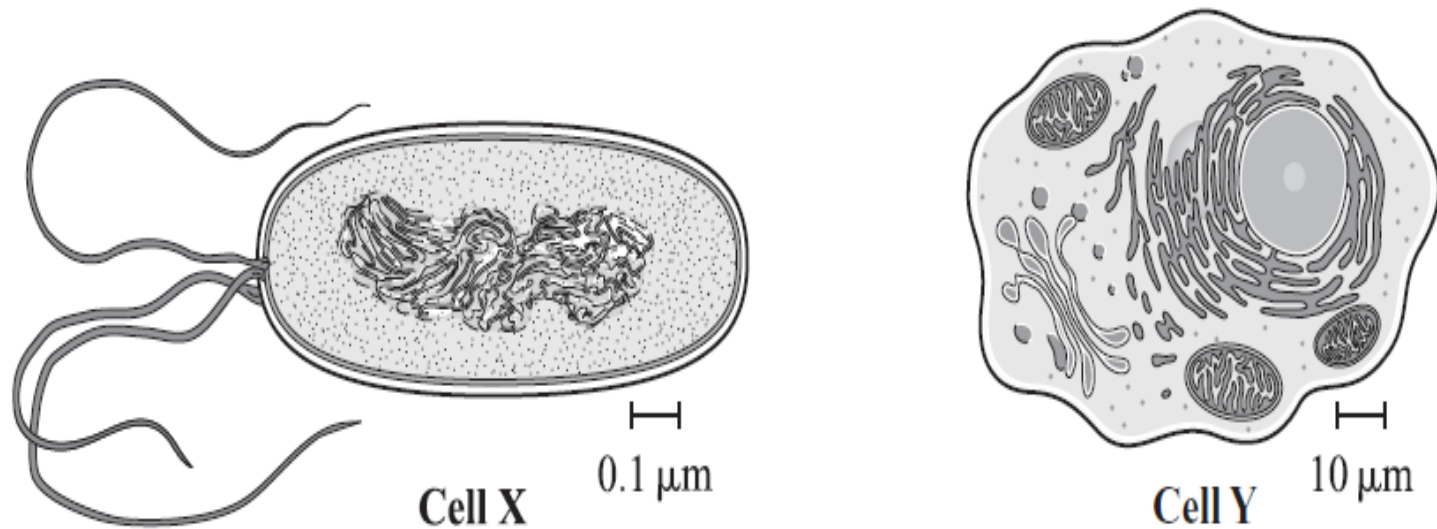

Which of the following statements **best** identifies these two cells?

- A. Cell X is a prokaryotic cell and cell Y is a eukaryotic cell.
- B. Cell X is an archae cell and cell Y is a eubacterial cell.
- C. Cell X is a red blood cell and cell Y is a muscle cell.
- D. Cell X is a plant cell and cell Y is an animal cell.

The diagram below shows a cross section of part of a cell membrane.

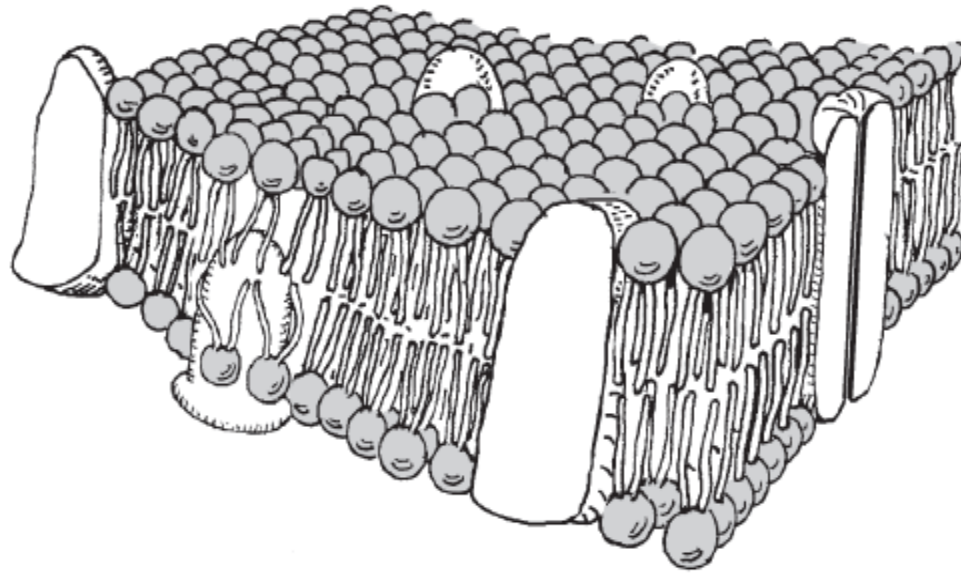

- a. Describe the basic structure of the cell membrane.
- b. Describe **two** primary functions of the cell membrane.
- c. Explain how the structure of the cell membrane allows it to perform the functions described in part (b).

A diagram of a plant cell is shown below.

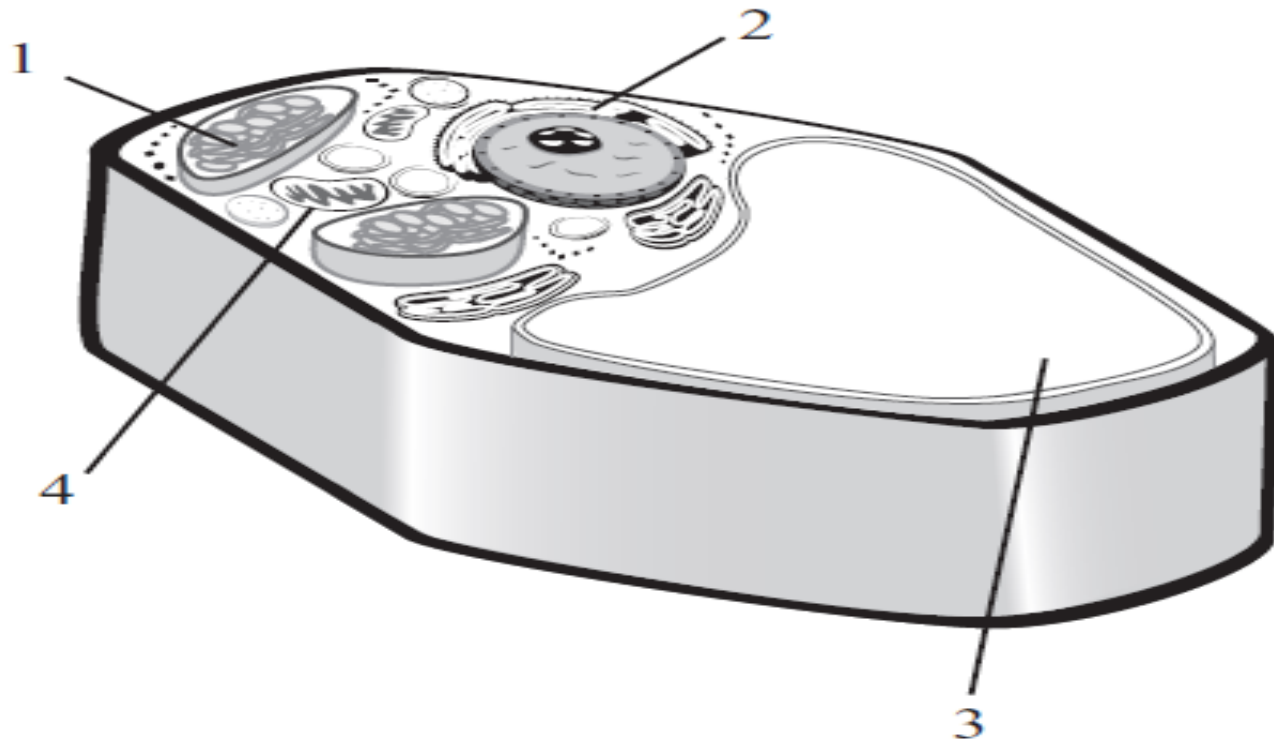

Which number identifies the organelle that functions to store water and dissolved salts?

- A. 1
- B. 2
- C. 3
- D. 4



Which of the following statements correctly describes the processes of photosynthesis and cellular respiration?

- A. Photosynthesis and cellular respiration occur in the same organelle.
- B. Photosynthesis and cellular respiration are performed by all organisms.
- C. Photosynthesis produces carbon dioxide, and cellular respiration uses carbon dioxide.
-  D. Photosynthesis stores energy for cells, and cellular respiration releases energy for cells.

15

The diagram below represents *Trichodina*.

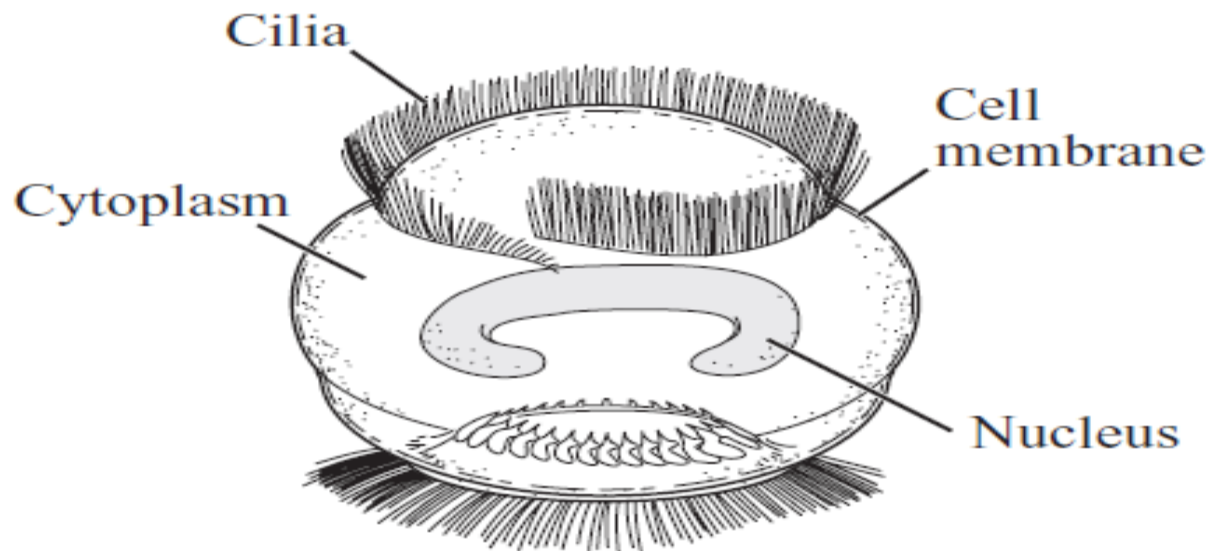

Trichodina is a eukaryotic organism that attaches itself to fish and eats bacteria. Which of the following distinguishes *Trichodina* from all prokaryotes?

- A. *Trichodina* is unicellular.
- B. *Trichodina* has a nucleus.
- C. *Trichodina* has cytoplasm.
- D. *Trichodina* is heterotrophic.



In a cell, which of the following organelles **most likely** contains digestive enzymes?

- A. centriole
- B. chloroplast
- C. lysosome
- D. ribosome



36

An equation for a biochemical reaction is shown below.

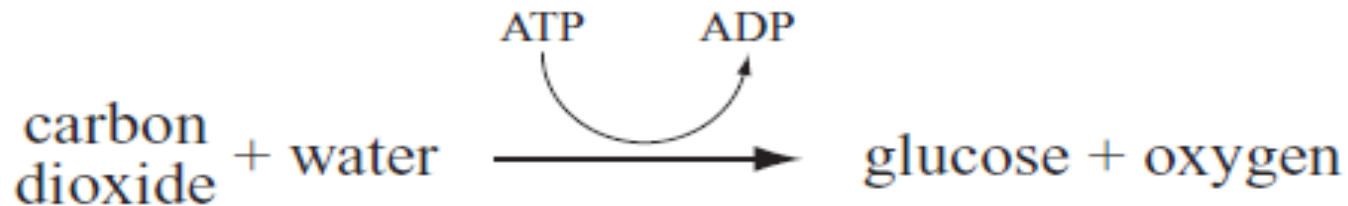

Which of the following happens during this reaction?



- A. Energy from ATP is used to make glucose.
- B. ADP adds a high-energy bond to its structure.
- C. ADP is metabolized to provide oxygen to a cell.
- D. Energy is stored in the molecule ATP for future use.